

second thermochemical cycle **B**, in which the difference between the CT

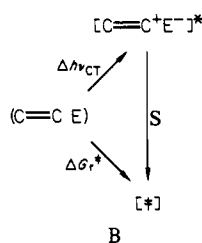

excited state $[\text{>C=C}^+\text{E}^-]^*$ and the transition state $[\ddagger]$ for electrophilic addition is labelled as **S**. We find that $\text{S} = \Delta G_r^* - \Delta h\nu_{\text{CT}}$ for bromination is the same as that for oxymercuration, i.e.,

$$(\Delta G_r^* - \Delta h\nu_{\text{CT}})_{\text{Br}_2} = (\Delta G_r^* - \Delta h\nu_{\text{CT}})_{\text{HgX}_2} \quad (12)$$

In other words, *path S is independent of the electrophile*. Such a situation would arise if the representation of the transition state were akin to the thermal ion pair, i.e., $[\ddagger] = [\text{>C=C}^+\text{E}^-]$. Under these circumstances the contribution from the electrophile would be minimal, if at all, owing to its cancellation in the comparative procedure. (We showed in a recent study³⁷ with alkylmetal donors that path **S** actually corresponds to a solvation change in the donor moiety as it proceeds from the excited ion pair to the thermal ion pair.)

The correlation with the CT transition energies in eq 12 is, in fact, equivalent to the correlation presented with the steric terms in eq 8 since it follows from eq 7 that $(\Delta h\nu_{\text{CT}})_{\text{Br}_2} - (\Delta h\nu_{\text{CT}})_{\text{HgX}_2} = \Delta E_{\text{Br}_2} - \Delta E_{\text{HgX}_2}$ for the same series of olefins with ΔI_D in common. Furthermore, the linear relationship observed in Figure 7 for the various electrophiles accords with the formulation in cycle **B** since the steric effect induced on a given olefin is not highly dependent on the electrophile.⁴⁷

Acknowledgment. We wish to thank the National Science Foundation for financial support.

Supplementary Material Available: Tables of the effects of bromine and olefin concentrations on the observed third-order rate constants for bromination in CCl_4 (Table IS) and spectral data for the EDA complexes of olefins with Br_2 , HgCl_2 , and $\text{Hg}(\text{OAc})_2$ (Table IIS) (3 pages). Ordering information is given on any current masthead page.

(47) With use of the comparative method, the change in the interaction energy with a series of electrophiles acting on a fixed olefin is given by $\Delta E = \Delta h\nu_{\text{CT}} + \Delta E_A$, owing to the cancellation of I_D from eq 10. Accordingly, the steric term for Br_2 relative to $\text{Hg}(\text{OAc})_2$ is $[(4.10 - 4.84) + (1.48 - 0.71)] / (2.3RT) = 0.5$, as evaluated for 4,4-dimethyl-2-pentene by using the data in Tables I and III. Thus, the difference of 0.5 is negligible compared to the large changes for \mathcal{E} in Table IV.

Gas-Phase Binding Energies and Spectroscopic Properties of NO^+ Charge-Transfer Complexes

W. D. Reents, Jr., and B. S. Freiser*

Contribution from the Department of Chemistry, Purdue University, West Lafayette, Indiana 47907. Received July 2, 1980

Abstract: The NO^+ affinities (NOA) of 28 bases were determined by using ion cyclotron resonance (ICR) spectrometry. The NOAs are observed to correlate with the proton affinities (PA) and the first ionization potentials (IP) of the bases for a specific class of compounds. The linearity with IP suggests that bonding to NO^+ is through the highest filled orbital. The photodissociation spectra of the NO^+ complexes were obtained as well. The NO^+ complexes of benzene, toluene, and mesitylene have λ_{max} at 327 nm and onsets for dissociation at 580 nm. The NO^+ complex of diethyl ether has a λ_{max} at 300 nm and an onset for dissociation at 450 nm. The NO^+ complex of ethanol has a λ_{max} at ≤ 240 nm and an onset for dissociation at 440 nm. The NO^+ complexes of ethyl acetate, acetone, and 3-pentanone have λ_{max} at 265 nm and an onset for dissociation at 580 nm. The NO^+ complexes of benzaldehyde and butyraldehyde have λ_{max} at 300 nm and an onset for dissociation at 460 nm. The NO^+ complex of diisopropyl ketone has a λ_{max} at 350 nm and an onset for dissociation at 580 nm. All these spectra exhibit a broad absorption band which is characteristic of charge-transfer complexes. It is evident that the spectra are nearly identical within a class of compounds. The similarity in the spectra for the NO^+ complexes of benzaldehyde and butyraldehyde indicates that NO^+ binds to the carbonyl group in benzaldehyde rather than the aromatic ring. When the site of charge changes from NO (as with 3-pentanone) to the base (as with diisopropyl ketone), the spectrum is altered considerably. Thus the site of charge in the complex may be determined by the photodissociation technique.

Interactions of ions and neutrals in solution have been of great interest for many years. With the advent of mass spectroscopic techniques, gas-phase studies of ion-neutral interactions have yielded a vast quantity of thermodynamic data as well as information on solvation of ions. These studies include the bonding of metal ions to bases (e.g., Cu^+ ,¹ Ag^+ ,^{1b,d} Fe^+ ,² Ni^+ ,^{2d} Co^+ ,^{2a,d,3}

Al^+ ,^{3a} Mn^+ ,³ Cr^+ ,³ Ti^+ ,³ Si^+ ,^{5a} SiH^+ ,^{5a} SiH_3^+ ,⁵ $\text{Si}(\text{CH}_3)^+$,⁶ CpNi^+ ,⁷ CH_3Hg^+ ,⁸ TiCl_3^+ ,⁹ SiCl_3^+ ,^{9b} and alkali ions^{1d,10}) as well as the

(1) (a) Burnier, R. C.; Carlin, T. J.; Reents, W. D., Jr.; Cody, R. B.; Lengel, R. K.; Freiser, B. S. *J. Am. Chem. Soc.* **1979**, *101*, 7127-7129. (b) Cody, R. B.; Burnier, R. C.; Reents, W. D., Jr.; Carlin, T. J.; McCreary, D. A.; Lengel, R. K.; Freiser, B. S. *Int. J. Mass Spectrom. Ion Phys.* **1980**, *33*, 37-43. (c) Burnier, R. C.; Byrd, G. D.; Freiser, B. S. *Anal. Chem.* **1980**, *52*, 1641-1650. (d) Castleman, A. W., Jr.; Holland, P. M.; Mark, T. D.; Peterson, K. I.; Keese, R. G.; Lee, N. "Proceedings of the 28th Annual Conference on Mass Spectrometry Allied Topics"; New York, 1980; pp 68-69. (e) Jones, R. W.; Staley, R. H. *Ibid.* pp 237-238.

(2) (a) Allison, J.; Ridge, D. P. *J. Organomet. Chem.* **1975**, *99*, C11-C14. (b) Foster, M. S.; Beauchamp, J. L. *J. Am. Chem. Soc.* **1975**, *97*, 4808-4814. (c) Dietz, T. G.; Chatellier, D. S.; Ridge, D. P. *J. Am. Chem. Soc.* **1978**, *100*, 4905-4907. (d) Allison, J.; Ridge, D. P. *J. Am. Chem. Soc.* **1979**, *101*, 4998-5009.

(3) Kappes, M. M.; Uppal, J. S.; Staley, R. H. "Proceedings of the 28th Annual Conference on Mass Spectrometry Allied Topics"; New York, 1980; pp 239-240.

(4) Hodges, R. V.; Armentrout, P. B.; Beauchamp, J. L. *Int. J. Mass Spectrom. Ion Phys.* **1979**, *29*, 375-390.

(5) (a) Allen, W. N.; Lampe, F. W. *J. Am. Chem. Soc.* **1977**, *99*, 2943-2948. (b) Allen, W. N.; Lampe, F. W. *J. Am. Chem. Soc.* **1977**, *99*, 6816-6822.

(6) Blair, I. A.; Bowie, J. H. *Aust. J. Chem.* **1979**, *32*, 1389-1393.

bonding of other ions to a variety of substrates (e.g., NO^+ ,¹¹ NO_2^+ ,^{11b,12} CH_3^+ ,¹³ F^- ,^{4,14} Cl^- ,^{4,14b} Br^- ,¹⁵ H^- ,^{14c,d,16} and, most importantly, H^+ ^{10f,14c,17}). These studies have shown that the acidity or basicity of various substrates is dependent on the ion examined.

The interest in NO^+ is fivefold: It is a stable ion in solution enabling a comparison between its gas-phase and solution properties.^{11a} The chemistry of NO^+ for application in chemical ionization has been previously examined.¹⁸ Also, the use of NO as a radical trap in radiolysis experiments may generate NO^+ whose reactivity would thus prove interesting. In addition, NO has an ionization potential roughly equal to the bases examined. The location of the charge in the NO^+ complexes (NO vs. substrate) would be desirable. Finally, NO^+ forms a charge-transfer complex with benzene.^{11a} Since the ionization potential of NO and benzene are so close (9.26 vs. 9.24 eV), an examination of additional substrates would show whether this is an exception or part of a large group of charge-transfer complexes. The possible existence of a group of charge-transfer complexes involving NO^+ would be a unique addition to the large collection of such complexes already studied.¹⁹

Experimental Section

The ion cyclotron resonance (ICR) spectrometer used in the present study is a modified V-5900 series manufactured by Varian Associates.

(7) Corderman, R. R.; Beauchamp, J. L. *J. Am. Chem. Soc.* **1976**, *98*, 3998–4000.

(8) (a) Stone, J. A.; Camicioli, R.; Baird, M. C.; Splinter, D. "Proceedings of the 28th Annual Conference on Mass Spectrometry Allied Topics"; New York, 1980; pp 65–67. (b) Bach, R. D.; Weibel, A. T.; Patane, J.; Kevan, L. *J. Am. Chem. Soc.* **1976**, *98*, 6237–6241.

(9) (a) Allison, J.; Ridge, D. P. *J. Am. Chem. Soc.* **1978**, *100*, 163–169. (b) Kinsler, R.; Allison, J.; Dietz, T. G.; deAngelis, M.; Ridge, D. P. *Ibid.* **1978**, *100*, 2706–2708.

(10) (a) Dzidic, I.; Kebarle, P. *J. Phys. Chem.* **1970**, *74*, 1466–1474. (b) Staley, R. H.; Beauchamp, J. L. *J. Am. Chem. Soc.* **1975**, *97*, 5920–5921. (c) Freiser, B. S.; Staley, R. H.; Beauchamp, J. L. *Chem. Phys. Lett.* **1976**, *39*, 49–52. (d) Davidson, W. R.; Kebarle, P. *J. Am. Chem. Soc.* **1976**, *98*, 6133–6138. (e) Freiser, B. S.; Beauchamp, J. L. *Ibid.* **1977**, *99*, 3214–3225. (f) Kebarle, P. *Annu. Rev. Phys. Chem.* **1977**, *28*, 445–476. (g) Woodin, R. L.; Beauchamp, J. L. *J. Am. Chem. Soc.* **1978**, *100*, 501–508. (h) Allison, J.; Ridge, D. P. *Ibid.* **1979**, *101*, 4998–5009. (i) Castleman, A. W., Jr.; Holland, P. M.; Lindsay, D. M.; Peterson, K. I. *Ibid.* **1978**, *100*, 6039–6045. (j) Sumner, J.; Nishizawa, K.; Kebarle, P. "Proceedings of the 28th Annual Conference on Mass Spectrometry Allied Topics"; New York, 1980; p 255.

(11) (a) Reents, W. D., Jr.; Freiser, B. S. *J. Am. Chem. Soc.* **1980**, *102*, 271–276. (b) Schulz, W.; Drost, H.; Klotz, H.-D. *Org. Mass Spectrom.* **1968**, *1*, 391–395. (c) Wolfshutz, R.; Schwarz, H. *Int. J. Mass Spectrom. Ion Phys.* **1980**, *33*, 291–297.

(12) Izod, T. P. J.; Tedder, J. M. *Proc. R. Soc. London, Ser. A*, **1974**, *337*, 333–350.

(13) Holtz, D.; Beauchamp, J. L.; Woodgate, S. D. *J. Am. Chem. Soc.* **1970**, *92*, 7484–7486.

(14) (a) Hartz, J. C.; McDaniel, D. H. *J. Am. Chem. Soc.* **1973**, *95*, 8562–8565. (b) Dawson, J. H. J.; Henderson, W. G.; O'Malley, R. M.; Jennings, K. R. *Int. J. Mass Spectrom. Ion Phys.* **1973**, *11*, 61–71. (c) Beauchamp, J. L. "Interactions between Ions and Molecules"; Ausloos, P.; Ed.; Plenum Press: New York, 1974. Kebarle, P. *Ibid.*, p 459. Bohme, D. K. *Ibid.*, p 489. (d) Blint, R. J.; McMahon, T. B.; Beauchamp, J. L. *J. Am. Chem. Soc.* **1974**, *96*, 1269–1278. (e) McMahon, T. B.; Blint, R. J.; Ridge, D. P.; Beauchamp, J. L. *Ibid.* **1972**, *94*, 8934–8936.

(15) Wieting, R. D.; Staley, R. H.; Beauchamp, J. L. *J. Am. Chem. Soc.* **1974**, *96*, 7552–7554.

(16) Solomon, J. J.; Meot-Ner, M.; Field, F. H. *J. Am. Chem. Soc.* **1974**, *96*, 3727–3732.

(17) (a) Brauman, J. I.; Blair, L. K. *J. Am. Chem. Soc.* **1970**, *92*, 5986–5992. (b) Bohme, D. K.; MacKay, G. I.; Schiff, H. I.; Hemsworth, R. S. *J. Chem. Phys.* **1974**, *61*, 2175–2179. (c) McIver, R. T., Jr.; Miller, J. S. *J. Am. Chem. Soc.* **1974**, *96*, 4323–4325. (d) Taft, R. W. "Proton-Transfer Reactions"; Caldin, E.; Gold, V.; Eds.; Wiley: New York, 1975; pp 31–77. (e) Wolf, J. F.; Staley, R. H.; Koppel, I.; Taagepera, M.; McIver, R. T., Jr.; Beauchamp, J. L.; Taft, R. W. *J. Am. Chem. Soc.* **1977**, *99*, 5417–5429.

(18) (a) Hunt, D. T.; Harvey, T. M. *Anal. Chem.* **1975**, *47*, 2136. (b) Williamson, A. D.; Beauchamp, J. L. *J. Am. Chem. Soc.* **1975**, *97*, 5714.

(19) (a) Mulliken, R. S. *J. Am. Chem. Soc.* **1950**, *72*, 600–608. (b) *Ibid.* **1952**, *74*, 811–824. (c) Briegleb, G. "Electronen-Donator-Acceptor-Komplexes"; Springer-Verlag: Berlin, 1961. (d) Foster, R. "Organic Charge-Transfer Complexes"; Academic Press: New York, 1969. (e) Mataga, N.; Kubota, T. "Molecular Interactions and Electronic Spectra"; Marcel Dekker: New York, 1970. (f) Yarwood, J. "Spectroscopy and Structure of Molecular Complexes"; Plenum Press: New York, 1973.

Scheme I

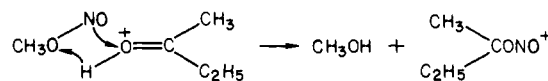

Table I. Heats of Reactions for Selected Bases

base	ΔH_{RXN} , kcal/mol		
	H ⁺ transfer (reaction 1)	NO ⁺ transfer (reaction 2)	concerted process (Scheme I)
EtOH	+5.3	-4.2	-9.5
C ₆ H ₅ F	+12.9	-6.8	-19.6
MeOAc	-3.7	-8.8	-4.5
MeEtCO	-5.3	-11.2	-5.8
C ₆ H ₅ Me	+3.0	-13.2	-16.1
(i-Pr) ₂ CO	-10	-13.6	-3.4

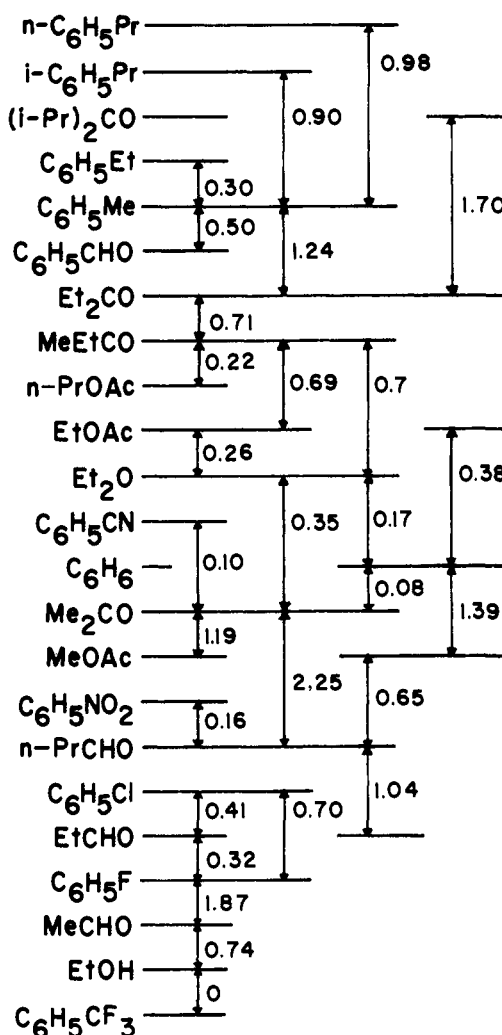

Figure 1. Directly measured standard free energies of NO^+ transfer (kcal/mol).

This instrument has been used extensively in this laboratory for studies of electron²⁰ and photon^{11a,21} excitation processes as well as for laser ionization studies.^{18-c} A 3.5-kW mercury-xenon arc lamp and a 0.25-m Schoeffel monochromator set for 10-nm resolution were used in conjunction with the ICR spectrometer for the photodissociation studies. The photodissociation onsets were determined by using Corning cutoff filters with the full-light setting of the monochromator. Several of the

(20) (a) Freiser, B. S. *Int. J. Mass Spectrom. Ion Phys.* **1978**, *26*, 39–47.

(b) Cody, R. B.; Freiser, B. S. *Anal. Chem.* **1979**, *51*, 547–551.

(21) (a) McCrery, D. A.; Freiser, B. S. *J. Am. Chem. Soc.* **1978**, *100*,

2902–2904. (b) Burnier, R. C.; Freiser, B. S. *Inorg. Chem.* **1979**, *18*, 906–907.

(c) McCrery, D. A. M.S. Thesis, Purdue University, 1979.

complexes were found to have onsets for photodissociation near the thermodynamic threshold for the process $\text{BNO}^+ \rightarrow \text{B} + \text{NO}^+$. In the absence of the actual absorption spectra, however, it could not be determined whether the photodissociation onsets were strictly thermodynamic or absorption onsets. The spectrum for the NO⁺ complex of mesitylene was obtained in solution by the method previously reported.^{11a}

Equilibrium measurements for the NO⁺ affinities were made with the two neutral gases mixed in the same gas bulb whenever possible to ensure accurate relative ratios of neutral gas. When the vapor pressure of one component was less than 5 torr, it was entered into the instrument by a separate inlet. The pressures inside the cell were then estimated by using an ionization gauge. The latter procedure was used for the alkylbenzenes except toluene and for nitrobenzene, cyanobenzene, and benzaldehyde. With both procedures the ion intensities were monitored as a function of time until equilibrium was attained (~ 2 s at $\sim 10^{-6}$ torr). Each free-energy difference represents the average of two or more determinations. Measurements were made at the ambient (~ 25 °C) cell temperature.

The relative reaction rates were obtained with the three reagent gases prepared in a single bulb with the pressures $\text{CH}_3\text{ONO}:\text{base 1}:\text{base 2} = 10:1:1$ where base 1 and base 2 represent the two bases in a rate study. The gas mixture was entered into the ICR spectrometer to a pressure of $\sim 10^{-6}$ torr. This method ensured a known pressure ratio of the bases as well as reproducible absolute pressures between the two measurements. The rates reported in the text are in arbitrary units.

Methyl nitrite was prepared by the literature method.²² All other chemicals were obtained commercially and used without further purification except for two freeze-pump-thaw cycles prior to gas-phase study to remove noncondensable gases.

Results and Discussion

Formation of Complexes and Affinities. Methyl nitrite serves as an excellent generator of NO⁺ complexes. Its high proton affinity (PA) combined with the low NO⁺ affinity (NOA) of methanol enables methyl nitrite to, in effect, transform protons (present as protonated bases) into NO⁺ (present as NO⁺ complexes). The energetics for competitive H⁺ and NO⁺ transfer from protonated methyl nitrite to selected bases (reactions 1 and 2,

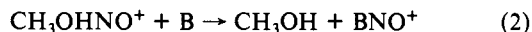
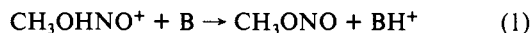

respectively) are illustrated in Table I. It is obvious that NO⁺ transfer from protonated methyl nitrite is favored thermodynamically over proton transfer. In those cases where proton transfer from the base to methyl nitrite is endothermic (e.g., methyl ethyl ketone), production of the NO⁺ complex from the protonated base (which is observed) may occur in a concerted process (cf. Scheme I) which is exothermic as shown in Table I. A similar reaction has been observed for $\text{CH}_3\text{COCH}_2^-$ attack on alkyl nitrites.²³

Additional reactions which produce NO⁺ complexes are identical with formation of the benzene/NO⁺ complex previously reported (excluding reaction of the base radical cation).^{11a}

Table II presents the NOAs for the bases examined in this study and obtained from other work as well as their proton affinities and ionization potentials (IP). Figure 1 illustrates the data from Table II graphically and demonstrates the overlapping measurements taken to check the NOAs. The values from this work are referenced to the NO⁺ affinity of ethanol obtained by Farid and McMahon²⁴ by using the proton affinity of ethyl nitrite (corrected for $\text{PA}(\text{NH}_3) = 208.4$ kcal/mol²⁵). Equilibrium measurements relating ethanol to the other bases yielded free energy differences. However, with the assumption that the entropy of NO⁺ transfer between bases is zero in these measurements, previously shown to be a good approximation for $\text{Li}^+ 10_{g,26}$ and

(22) Hartung, W. H.; Crossley, F. "Organic Syntheses"; Blatt, A. H.; Ed.; Wiley: New York, 1943; Collect. Vol. II, pp 363-364.

(23) King, G. K.; Marieq, M. M.; Dupey, C. H. "Proceedings of the 28th Annual Conference on Mass Spectrometry Allied Topics"; New York, 1980; pp 577-578.

(24) Farid, R.; McMahon, T. B. *Int. J. Mass Spectrom. Ion Phys.* **1978**, *27*, 163-183.

(25) Houle, F. A.; Beauchamp, J. L. *J. Am. Chem. Soc.* **1979**, *101*, 4067-4074.

(26) Searles, S. K.; Kebarle, P. *Can. J. Chem.* **1969**, *47*, 2619-2627.

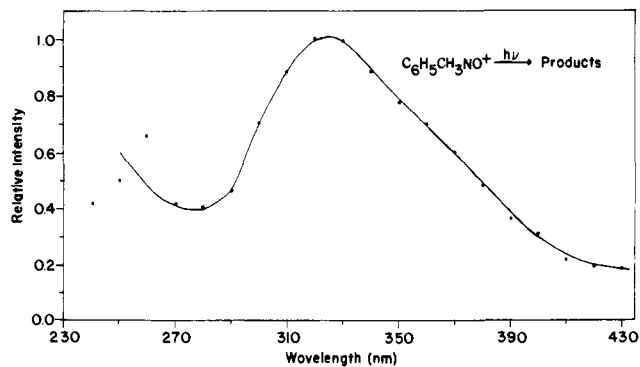

Figure 2. The photodissociation spectrum of the NO⁺ complex of toluene.

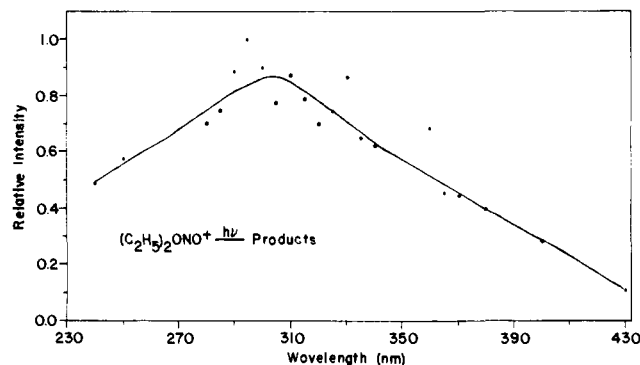
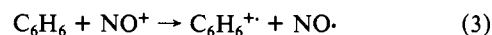

Figure 3. The photodissociation spectrum of the NO⁺ complex of diethyl ether.

$\text{K}^+ 10_{g,f}$ affinities, then the free-energy differences closely approximate the enthalpy differences for NO⁺ transfer. The relative NOAs benzene < toluene < pyridine²⁷ differ from the data of Schulz et al.^{11b} which indicates that their system had apparently not attained equilibrium.

Nature of Complex. NO⁺ is a unique acid. Other acids have either a very high electron affinity (e.g., H⁺) or a very low electron affinity (e.g., alkali ions) relative to typical bases so that the location of the charge is not in doubt. For NO⁺, however, its electron affinity (9.26 eV²⁸) is the same magnitude as typical bases. The location of the charge is not a certainty and may depend upon the IP of the base.

In a previous study^{11a} the NO⁺ complex of benzene was examined. This complex, found to be a charge-transfer (CT) complex and stable toward isomerization to protonated nitrosobenzene, was believed to have the charge contained predominantly on the benzene moiety due to the extent of reaction 3 ($K_{\text{eq}} =$



119²⁹). Since the IPs of benzene and NO are roughly equivalent (9.24 and 9.26 eV, respectively), using a base with a greater IP should alter the charge distribution in the complex. A photodissociation spectrum (an indirect determination of an ion's UV absorption spectrum³⁰) would be useful to test this hypothesis since it examines the electronic structure of the ion. The absorption maxima of CT complexes are predicted to be a function of the IP of the base.¹⁹

The photodissociation spectra for the NO⁺ complexes studied are divided into several groups. The NO⁺ complexes of benzene, toluene and mesitylene exhibit spectra, as shown in Figure 2 for the NO⁺ complex of toluene, with a maximum at 327 nm and an onset for dissociation at 580 nm. The NO⁺ complex of diethyl

(27) We have found $\text{NOA}(\text{pyridine}) > \text{NOA}(\text{toluene})$.

(28) Lias, S. G. *Chem. Phys. Lett.* **1978**, *54*, 147-153.

(29) Lias, S. G.; Ausloos, P. *J. Am. Chem. Soc.* **1977**, *99*, 4831-4833.

(30) Dunbar, R. C. "Ion Molecule Interactions"; Ausloos, P., Ed.; Plenum Press: New York, 1975.

Table II. NO⁺ Affinities, Ionization Potentials, and Proton Affinities

base	NOA ^a	IP ^b	PA ^c
NO	13.6 ^d	9.26	124.9 ^l
H ₂ O	18.5 ^e	12.60	176.4
MeOH	36.2 ^f	10.84	188.3
EtOH	40.4 ^f	10.47	192.5
C ₆ H ₅ CF ₃	~40.4 ^o	9.68	178.2 ^j
MeCHO	41.14	10.22	191.1
<i>t</i> -BuOH	41.2 ^{f,p}	~10.1 ^g	197.5 ^k
<i>i</i> -PrOH	42.6 ^{f,p}	10.15	195.5 ^k
C ₆ H ₅ F	43.01	9.20	184.9 ^e
EtCHO	43.33	9.96	194.1
C ₆ H ₅ Cl	43.74	9.06	185.1 ^e
<i>n</i> -PrCHO	44.37	9.80	195.8
C ₆ H ₅ NO ₂	44.53	~9.9	197.2 ^e
MeOAc	45.02	10.27	201.5
Me ₂ CO	46.21	9.70	200.0
C ₆ H ₆	46.29	9.24	186.2 ^e
C ₆ H ₅ CN	46.3	9.70	199.7 ^e
Et ₂ O	46.46	9.51	203.5
EtOAc	46.72	10.10	204.2
<i>n</i> -PrOAc	47.19	10.04	204.7 ^e
MeEtCO	47.41	9.51	203.1 ^l
Et ₂ CO	48.12	9.32	204.6 ^l
C ₆ H ₅ CHO	48.86	9.4 ^h	203.7 ^e
C ₆ H ₅ Me	49.36	8.82	194.8
C ₆ H ₅ Et	49.66	8.76	195.7
(<i>i</i> -Pr) ₂ CO	49.82	8.96	208 ^m
<i>i</i> -C ₆ H ₅ Pr	50.26	8.69	196.9 ⁿ
<i>n</i> -C ₆ H ₅ Pr	50.34	8.72	196.5

^a In kcal/mol. Data are from this work unless noted otherwise. Relative values are ± 0.20 kcal/mol for this work. Absolute values (except for NO, H₂O, MeOH, *i*-PrOH, and *t*-BuOH) are relative to NOA (EtOH) from footnote *f* below. ^b In eV. The following reference was used unless noted otherwise: Rosenstock, H. M.; Drakl, K.; Steiner, B. W.; Herron, J. T. *J. Phys. Chem. Ref. Data, Suppl.* 1977, 6, No. 1. ^c In kcal/mol based upon PA(NH₃) = 208.4 kcal/mol. The following reference was used unless noted otherwise: Wolf, J. F.; Staley, R. H.; Koppel, I.; Taagepera, M.; McIver, R. T., Jr.; Beauchamp, J. L.; Taft, R. W. *J. Am. Chem. Soc.* 1977, 99, 5417-5429. ^d Ng, C. Y.; Tiedemann, P. W.; Mahan, B. H.; Lee, Y. T. *J. Chem. Phys.* 1977, 66, 3985-3987. ^e Kebarle, P. *Annu. Rev. Phys. Chem.* 1977, 28, 445-476. ^f Corrected for PA(NH₃) = 208.4 kcal/mol: Farid, R.; McMahon, T. B. *Int. J. Mass Spectrom. Ion Phys.* 1978, 27, 163-183. ^g Average of two values: 9.97 and 10.23 eV; footnote *b* above. ^h Rabalais, J. W.; Colton, R. J. *J. Electron Spectrosc.* 1972/1973, 1, 83-99. ⁱ Calculated from *H*₂'s (footnote *b* above) and IP(DNO⁺) = 10.29 eV: Kohout, F. C.; Lampe, F. W. *J. Chem. Phys.* 1966, 45, 1074-1075. ^j From STO-3G calculation; corrected for PA(NH₃) = 208.4 kcal/mol: McKelvey, J. M.; Alexandratos, S.; Streitweiser, A., Jr.; Abboud, J.-L. M.; Hehre, W. J. *J. Am. Chem. Soc.* 1976, 98, 244-246. ^k Adjusted to agree with PA(EtOH) = 192.5 kcal/mol: Hiraoka, K.; Kebarle, P. *J. Am. Chem. Soc.* 1977, 99, 360-366. ^l Beauchamp, J. L., private communications. ^m This work. Estimated from equilibrium measurement with (*i*-Pr)₂O, PA((*i*-Pr)₂O) = 209.1 kcal/mol: Beauchamp, J. L., private communications. ⁿ Corrected for PA(NH₃) = 208.4 kcal/mol: Hehre, W. J.; McIver, R. T., Jr.; Pople, J. A.; Schleyer, P. v. R. *J. Am. Chem. Soc.* 1974, 96, 7162-7163. ^o Estimated by observation of equilibrium with EtOH through double-resonance examination. Interfering reactions prevented exact determination. ^p Interfering reactions prevented direct determination of NOA.

ether illustrated in Figure 3 has a maximum at 300 nm and an onset for dissociation at 450 nm. The NO⁺ complex of ethanol illustrated in Figure 4 has a maximum at ≤ 240 nm and an onset for dissociation at 440 nm. The NO⁺ complexes of ethyl acetate, acetone, and 3-pentanone exhibit spectra, as shown in Figure 5 for the NO⁺ complex of 3-pentanone, with a maximum at 265 nm and an onset for dissociation at 580 nm. The NO⁺ complexes of butyraldehyde and benzaldehyde exhibit spectra, as shown in Figure 6 for the NO⁺ complex of benzaldehyde, with a maximum at 300 nm and an onset for dissociation at ~ 460 nm. Thus far it appears that the spectra are identical within a class of compounds but differ between classes (the ester and ketones may be similar

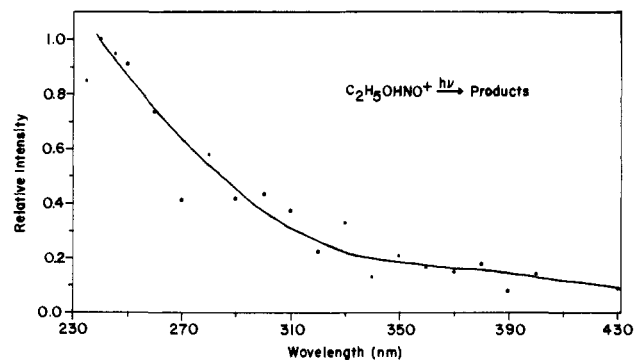
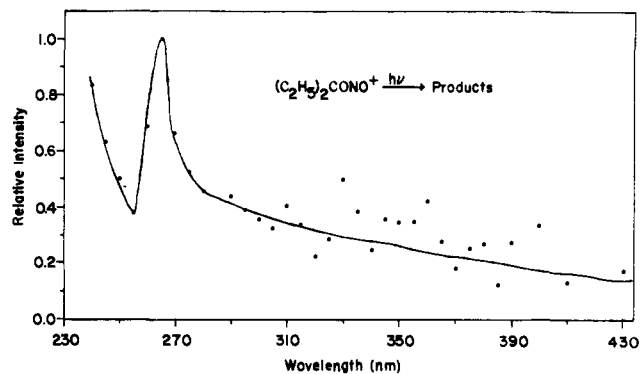
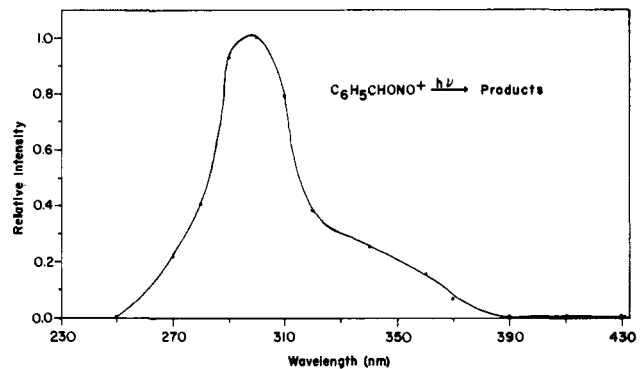
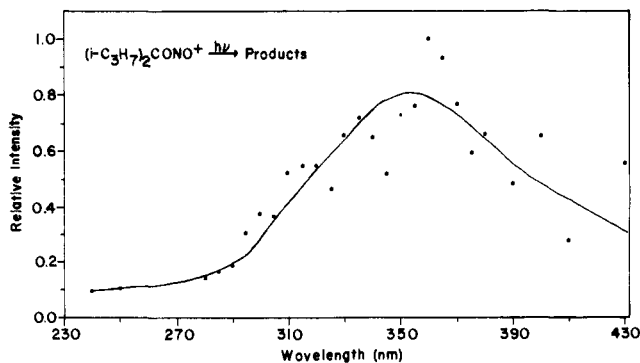
Figure 4. The photodissociation spectrum of the NO⁺ complex of ethanol.Figure 5. The photodissociation spectrum of the NO⁺ complex of 3-pentanone.Figure 6. The photodissociation spectrum of the NO⁺ complex of benzaldehyde.Figure 7. The photodissociation spectrum of the NO⁺ complex of diisopropyl ketone.

because NO⁺ is presumably bound to a disubstituted carbonyl group in both cases (vide infra)). However, a drastic change is observed with the NO⁺ complex of diisopropyl ketone relative to the other ketones examined. Its spectrum, shown in Figure 7, has

Table III. Least-Squares Analysis

NOA vs. PA			bases	NOA vs. IP		
slope	intercept	linear correlation coeff		slope	intercept	linear correlation coeff
0.89	156	0.681	all bases ^a	-0.116	14.9	0.894
1.20	142	0.588	all bases (exc H ₂ O) ^a	-0.125	15.3	0.776
2.20	99	0.998	ketones	-0.208	19.4	0.997
1.50	134	0.998	acetates	-0.104	15.0	0.999
1.44	132	0.999	alkylaldehydes	-0.128	15.5	0.998
1.65	123	0.998	aldehydes and benzaldehyde	-0.105	14.5	0.994
1.76	111	0.761	all aromatics	-0.086	13.2	0.674
1.51	130	1.000	nitrobenzene, cyanobenzene, and benzaldehyde	-0.116	15.0	1.000
1.8	106	0.982	halo- and alkylbenzenes	-0.083	12.9	0.929
			halo- and alkylbenzenes ^b (corrected)	-0.136	15.6	0.985
1.29	142	0.889	alcohols	-0.116	15.1	0.938
0.76	162	0.993	alcohols and water (exc <i>t</i> -BuOH)	-0.100	14.5	0.999
1.11	148	0.997	alcohols (exc <i>t</i> -BuOH)	-0.105	14.7	0.991
1.11	148	0.998	alcohols (corrected <i>t</i> -BuOH) ^c	-0.107	14.7	0.995

^a These analyses exclude the base NO. ^b Correction involves use of second IP of halobenzenes in analysis as discussed in the text. ^c Uses corrected NOA(*t*-BuOH) = 44.28 kcal/mol and IP(*t*-BuOH) = 9.97 eV in analyses as discussed in the text.

an absorption maximum at 350 nm and an onset for dissociation at 580 nm. The difference may be attributed to the low IP of diisopropyl ketone (8.96 eV) whereas the acetate and ketones have IPs greater than NO. This example demonstrates that the charge location (base vs. NO) is dependent upon the IP of the base and may be determined by the photodissociation spectra of the complexes. Since both toluene and mesitylene have considerably lower IPs than NO and their NO⁺ complexes exhibit spectra nearly identical with the spectrum of the NO⁺ complex of benzene, this supports the notion that the charge in these aromatic complexes is predominantly on the aromatic. It is also conceivable that the site of NO⁺ bonding in multifunctional compounds may be obtained by this method.³¹

These UV spectra are not all inclusive. Smith and Lee³² obtained the photodissociation spectrum of NONO⁺ which exhibited a maximum at ~650 nm. This is evidently a special case possibly because the base is a radical. The different nature of NO is further indicated by its anomalously high NOA relative to its PA (cf. Table II). In addition, Smith and Lee examined the photodissociation spectra of H₂ONO⁺, (H₂O)₂NO⁺, CO₂NO⁺, and N₂NO⁺. In these cases they merely noted no photodissociation at wavelengths greater than 350 nm. Evidently the bases have such high IPs that charge transfer is negligible. This is supported by the photodissociation spectrum of MeONONO⁺ (the IP of MeONO is 10.6 eV³³) shown in Figure 8 which has an onset for dissociation at 370 nm. The absorption may be predominantly due to methyl nitrite whose onset for absorption is at 380 nm.³⁴ Without the CT transition the complexes examined by Smith and Lee absorb only at much higher energies.

Since there are two distinct types of NO⁺ complexes, the charge predominantly on the base or on NO, the process of NO⁺ transfer in the gas phase will involve electron rearrangement for those complexes whose base contain the charge. Such a process could involve a high energy intermediate which would slow the transfer reaction. To test this, we determined relative reaction rates for NO⁺ transfer for the bases benzene, acetone, and diethyl ether (reactions 4 and 5). The relative rates are $k_1 = 11$, $k_{-1} = 6.3$,

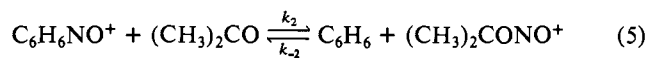
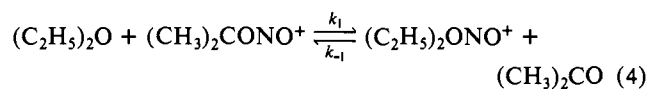

(31) This has been done for site of Li⁺ attachment to *p*-methoxybenzaldehyde.^{10e}

(32) Smith, G. P.; Lee, L. C. *J. Chem. Phys.* **1978**, *69*, 5393-5399.

(33) Hsieh, T.; Gilman, J. P.; Weiss, M. J.; Meisels, G. G. "Proceedings of the 28th Annual Conference on Mass Spectrometry Allied Topics"; New York, 1980; pp 418-419.

(34) Yoffe, A. D.; Gray, P. J. *Chem. Soc.* **1951**, 1412-1414.

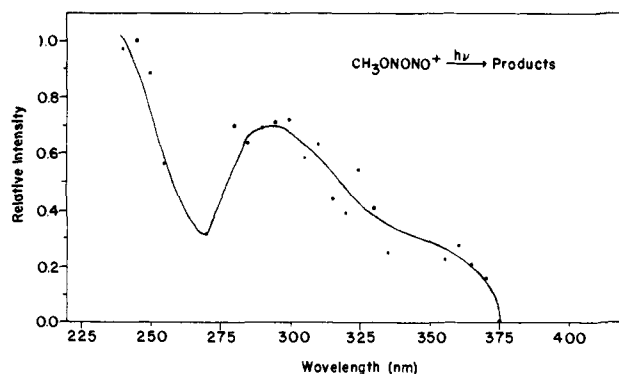

Figure 8. The photodissociation spectrum of the NO⁺ complex of methyl nitrite.

$k_2 = 11$, and $k_{-2} = 9.6$. It is evident that the reaction rates are comparable for the acetone/diethyl ether system where electron rearrangement would not be expected and the acetone/benzene system where electron rearrangement would be expected. Thus any electron rearrangement which occurs does not present a barrier to NO⁺ transfer.

A comparison between NO⁺ complexes and CT complexes in solution is warranted. Typical bond strengths for CT complexes are 1-4 kcal/mol and strong complexes have bond strengths of ~10 kcal/mol.^{18e,35} For gaseous NO⁺ complexes, typical bond strengths are 35-50 kcal/mol due to a more complete charge transfer as well as the additional effect of electrostatic attraction as has been noted by Kroeger and Drago.³⁶ Weak CT complexes exhibit a roughly linear relation between absorption maxima and base IP.¹⁹ This relationship breaks down for strong CT complexes such as amines with I₂³⁵ and appears to be nonexistent for NO⁺ complexes, again attributable to the large bond strengths involved. The broad-band absorption with high intensity which is characteristic of CT complexes is, however, present for NO⁺ complexes.

Data Correlation and Analysis. A plot of PA vs. NOA is presented in Figure 9. There is a considerable scatter in the points but linearity within a class of compounds is evident from the least-squares evaluation of the data presented in Table III. The overall slope is representative of the individual slopes but is only useful as a rough estimate for the NOA of compounds based upon their PA. The slopes based upon compound class are a more useful tool for predicting NOAs. Adding various substituents affect the PA and NOA of a compound class similarly resulting in the observed linearity. The small data set within each class limit the

(35) (a) Nagakura, S. *J. Chem. Soc.* **1958**, *80*, 520-524. (b) Yada, H.; Tanaka, J.; Nagakura, S. *Bull. Chem. Soc. Jpn.* **1960**, *33*, 1660-1667.

(36) Kroeger, M. K.; Drago, R. S., submitted for publication in *J. Am. Chem. Soc.*

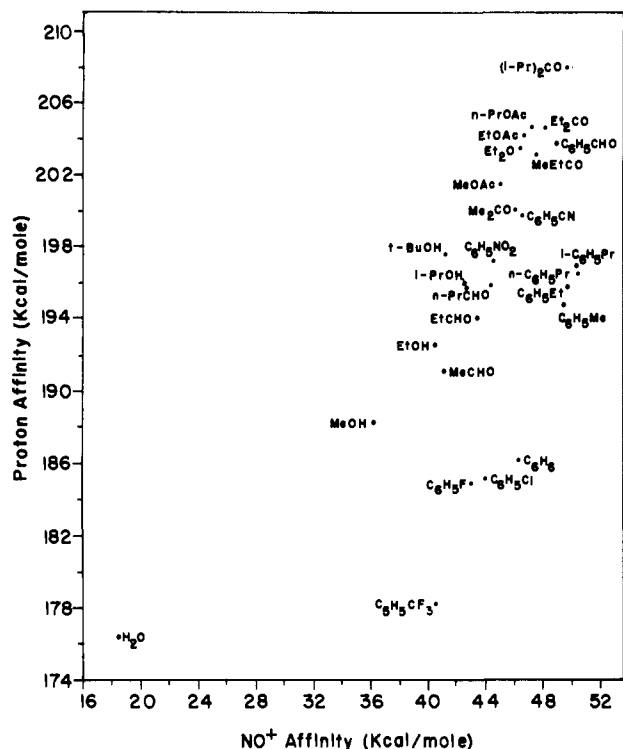

Figure 9. Comparison of proton affinity and NO^+ affinity of the bases examined.

certainty of any predictions. It is comforting, however, to see that water correlates well with the alcohols, indicating that not all attempts at analysis need to be abandoned.

The bases benzene, fluorobenzene, and chlorobenzene present a wider variation in NOA than PA which is a surprising result. The value for *tert*-butyl alcohol deviates significantly from the linearity present for the remaining alcohols. This may be due to an inaccurate estimate for its NOA which was calculated by using a group equivalent method for the heat of formation of *tert*-butyl nitrite.²⁴ Assuming its PA is correct, then the expected NOA of *tert*-butyl alcohol (extrapolated from the NOA of the alcohols) is 44.28 kcal/mol. This infers a heat of formation for *tert*-butyl nitrite of -42 kcal/mol by using the PA(*tert*-butyl nitrite) = 210 kcal/mol reported by Farid and McMahon²⁴ (corrected for PA(NH_3) = 208.4 kcal/mol²⁵) which differs slightly from their estimated value of -46 kcal/mol.

Benzaldehyde, cyanobenzene and nitrobenzene do not correlate with the other aromatics but do correlate within themselves. This suggests that, like H^+ ,^{37,38} NO^+ is bound to the substituent. This is supported by the excellent correlation of benzaldehyde with the alkylaldehydes and the fact that the photodissociation spectra of the NO^+ complexes of benzaldehyde and butyraldehyde match.

Figure 10 presents a plot of IP vs. NOA. As with the PA plots, linearity within groups are observable as shown by the least squares analysis in Table III. Again water correlates well with the alcohols. Beauchamp et al.³⁹ have demonstrated that a plot of PA vs. IP with nitriles is linear if the IP of the orbital involved in bonding to the proton is used. Therefore the aldehydes, ketones, and esters⁴⁰ presumably bond to NO^+ through their unpaired electrons on their carbonyl oxygen, and the alcohols and ethers⁴¹ bond through their unpaired electrons on oxygen. There is some dif-

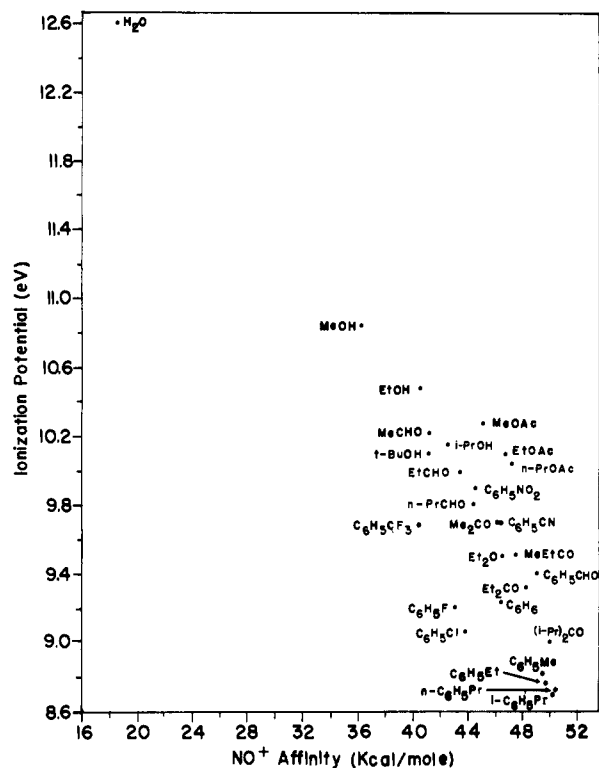

Figure 10. Comparison of ionization potential and NO^+ affinity of the bases examined.

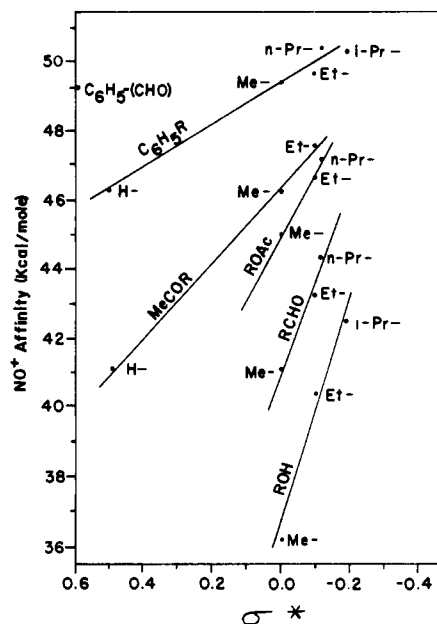

Figure 11. Comparison of NO^+ affinity and Taft's σ^* for classes of compounds.

ficulty with the aromatics, however. Benzaldehyde, cyanobenzene, and nitrobenzene again deviate from linearity with the alkylbenzenes but correlate within themselves. Their first IPs have been assigned to their aromatic π electrons⁴² which would suggest that NO^+ bonds through these π electrons. However, since their NOAs were found to correlate with their PAs, which had suggested bonding through their substituent, and since benzaldehyde correlates well (both IP and PA vs. NOA) with the alkylaldehydes (cf. Table III) and the photodissociation spectra of benzaldehyde and butyraldehyde match, then the first IPs of these aromatics

(37) Lau, Y. K.; Kebarle, P. *J. Am. Chem. Soc.* **1976**, *98*, 7452-7453.

(38) BF_3 also bonds to carbonyl of benzaldehyde: Rabinovitz, M.; Grinvald, A. *J. Am. Chem. Soc.* **1972**, *94*, 2724-2729.

(39) Staley, R. H.; Kleckner, J. E.; Beauchamp, J. L. *J. Am. Chem. Soc.* **1976**, *98*, 2081-2085.

(40) The nonbonding electrons on the carbonyl oxygen of aldehydes, ketones, and esters should be the highest energy since the $n \rightarrow \pi^*$ transition is lower in energy than the $\pi \rightarrow \pi^*$ transition for carbonyls.

(41) The highest occupied orbital for alcohols and ethers corresponds to the unpaired electrons on oxygen: Al-Joboury, M. I.; Turner, D. W. *J. Chem. Soc. B* **1967**, 373-376.

(42) The highest occupied orbital for benzaldehyde, cyanobenzene, and nitrobenzene has been assigned to their aromatic π electrons: Baker, A. D.; May, D. P.; Turner, D. W. *J. Chem. Soc. B* **1968**, 22-34.

should correspond to nonbonding electrons on their substituent. Significant deviation from linearity with the alkyl aromatics is also observed for fluorobenzene, chlorobenzene, and trifluorotoluene. However, linearity is improved and a slope in better agreement with the other slopes may be obtained by using their second ionization potentials (9.87,⁴³ 9.64,⁴⁴ and ~9.9 eV⁴⁵ for fluorobenzene, chlorobenzene, and trifluorotoluene, respectively) which also correspond to aromatic π electrons. The significance of these results will be discussed in detail in view of theoretical calculations in a subsequent paper.

Deviation from linearity with the alcohols is observed for *tert*-butyl alcohol, but its IP is in dispute with values of 9.97⁴⁶ and 10.23 eV⁴⁷ having been reported (the average was used for the plots). If we use the "corrected" NOA of *tert*-butyl alcohol previously calculated (44.28 kcal/mol), we find that the IP of 9.97 eV gives a good correlation (cf. Table III), suggesting that the value of 10.23 eV is in error.

Taft has derived a set of parameters, σ^* , which indicate the polarizability effects (i.e., ability to withdraw electrons) of substituent groups separated from steric effects.⁴⁸ Plots of NOA

vs. σ^* for classes of compounds (cf. Figure 11) yield straight lines for the alcohols, aldehydes, ketones, acetates, and alkylbenzenes, indicating that the polarizability of the substituents explains the variation of NOA within a class of compounds. Benzaldehyde does not correlate with the alkylaldehydes, however, indicating that the phenyl group, rather than withdrawing electrons, donates electrons. This suggests that additional interaction by the phenyl group, e.g., resonance stabilization of the charge, is involved.

In summary, we have found that the location of the charge (base vs. NO) in the complex is dependent upon the base's IP. Photodissociation spectra of the complexes are virtually identical within a class of bases but differ between classes. However, the spectra change when the location of the charge in the complex changes. Bases with high IP (≥ 11 eV) form complexes which do not exhibit the charge-transfer spectra evident in the other complexes. The NO⁺ affinities are observed to correlate with the proton affinities and the ionization potentials of the bases for a given class of compounds. Deviations are attributable to differences in bonding and, for the ionization potentials, the involvement of lower lying orbitals in bonding to NO⁺. In a subsequent paper, experimental and theoretical properties of aromatic NO⁺ π complexes will be examined.

Acknowledgment. This work was supported in part by the Research Corp. through a Cottrell Research Grant. The authors also wish to acknowledge the donors of the Petroleum Research Fund, administered by the American Chemical Society.

(43) Clark, I. D.; Frost, D. C. *J. Am. Chem. Soc.* **1967**, *89*, 244-247.

(44) Sergeev, Y. L.; Akopyan, M. E.; Vilesov, F. I.; Kleimenov, V. I. *Opt. Spectrosc. (Eng. Transl.)* **1970**, *29*, 63-65.

(45) Estimated from photoelectron spectrum of trifluorotoluene: Turner, D. W.; Baker, C.; Brundle, C. R. "Molecular Photoelectron Spectroscopy"; Wiley-Interscience: New York, 1970; p 293.

(46) Cocksey, B. J.; Eland, J. H. D.; Danby, C. J. *J. Chem. Soc. B* **1971**, 790-792.

(47) Baker, A. D.; Betteridge, D.; Kemp, N. R.; Kirby, R. E. *Anal. Chem.* **1971**, *43*, 375-381.

(48) Taft, R. W., Jr. "Steric Effects in Organic Chemistry"; Newman, M. S., Ed.; Wiley: New York, 1956.

Redox Chemistry of *N*⁵-Ethyl-3-methylflavinium Cation and *N*⁵-Ethyl-4a-hydroperoxy-3-methylflavin in Dimethylformamide. Evidence for the Formation of the *N*⁵-Ethyl-4a-hydroperoxy-3-methylflavin Anion via Radical-Radical Coupling with Superoxide Ion

Edward J. Nanni, Jr.,[†] Donald T. Sawyer,*[‡] Sheldon S. Ball,[†] and Thomas C. Bruce[†]

Contribution from the Departments of Chemistry, University of California, Riverside, California 92521, and University of California, Santa Barbara, California 93106. Received September 15, 1980

Abstract: The oxidation-reduction chemistry of the *N*⁵-ethyl-3-methylflavinium ion (FlEt³⁺), its reduction products, its hydroperoxide (4a-FlEtOOH), and the adduct formed by the combination of the *N*⁵-ethyl-3-methylflavinoxyl radical (FlEt•) and superoxide ion (O₂⁻) in dimethylformamide has been determined by cyclic voltammetry, controlled potential coulometry, UV-visible spectroscopy, and ESR spectroscopy. The FlEt³⁺ cation exhibits four reduction steps at +0.28, +0.07, -0.36, and -1.14 V (vs. SCE) with electron stoichiometries for the first three steps of 0.5, 1.0, and 1.5 electrons/molecule, respectively, and a single reversible one-electron oxidation at +1.04 V. Electrochemical measurements indicate that several binuclear adducts are formed during electrolytic reduction of FlEt³⁺; these include [(FlEt²⁺)(FlEt•)], (FlEt•)₂, and [(FlEt•)(FlEt²⁺)]. Combination of FlEt• and O₂⁻ results in the transient formation of the *N*⁵-ethyl-3-methylflavinoxylperoxide anion (4a-FlEtOO⁻). The species 4a-FlEtOOH and 4a-FlEtOO⁻ are effective reaction mimics for flavo mono- and dioxygenases.

In biological redox chemistry the flavoproteins function as intermediates between obligate two-electron donors and obligate one-electron acceptors and as O₂ activators in the net two-electron reduction of O₂ to H₂O₂ and in the net four-electron reductive

activation and cleavage of O₂ in monooxygenation reactions.¹ The isoalloxazine ring is the redox active component in these enzymes; however, there is not universal agreement concerning the mechanistic details of the electron-transfer processes^{2,3} and of the

[†]University of California, Riverside.

[‡]University of California, Santa Barbara.

(1) Walsh, C. *Acc. Chem. Res.* **1980**, *13*, 148.

(2) Sawyer, D. T.; Komai, R. Y. *Anal. Chem.* **1972**, *44*, 715.